



MDHB

A HALF WAVE DIPOLE RADIATOR, PROVIDING EFFICIENT VHF PERFORMANCE IN TRANSMIT AND RECEIVE MODES FOR MARINE OR LAND VHF MARINE BAND COMMUNICATIONS

The MD is lightweight, unobtrusive and easily mounted, being constructed of marine grade, low corrosion, tempered aluminium tubing. The radiator is finished with a high durability epoxy based coating, highly resistant to chemical attack, abrasion and the effects of ozone and ultra-violet radiation. Standard colour is black with option of white. All metal parts are at DC earth potential for static discharge and fittings are of nylon and stainless steel.

Mounting may be affected either by two nylon clamp type insulators, M12 bolt, or by a swingdown mount. Other methods, such as stainless steel hose clamps, may be used provided that the mounting tube is insulated. A stainless steel spring mount is also available as an option for landing barges and vessels negotiating overhanging branches in small rivers and creeks.

It may be supplied tuned to any frequency in the VHF High or Low/Mid Bands. If required for VHF ▶

SPECIFICATIONS ▼

	Standard	Optional
Colour	Black	White
Frequency Range	146-180MHz (centre frequency tuneable within this range)	
Polarisation	Vertical , Omnidirectional	
Power	80 watts	
Bandwidth	7MHz VSWR of < 2:1 within a 7MHz Bandwidth, within the frequency range of 146 - 180MHz	
VSWR	< 1.2:1 at centre frequency	
Gain	2.2 dBi	
Impedance	50 ohms (nominal)	
Length	1.59m approx	
Section Diameter	Base: 22mm Top: 12.7mm	
Wind Loading	1.64 kg at 100 km/h; 3 kg at 130 km/h 2.3 kg at 100 km/h; 4.17 kg at 130 km/h Wind Survival 175 km/h	
Temperature	-50 to +55°C 100% humidity	
Connection	5 metres RG58 coaxial cable with PL259 (UHF) connector; or female N Type connector permanently fitted in base of mounting tube ("U" mounting type)	
Mounting (see illustration)	U: Connector in base (no cable), Side mounted via insulators or clamps 1: Base fed cable with connector, Side mounted via insulators or clamps 2: Side fed cable with connector, Base mount with M12 bolt 3: Side fed cable with connector, Base mount with 1" x 14 TPI 4: Base fed cable with connector, Base mount with 1" x 14 TPI	
Weight	Antenna only: 0.7kg Packed: 1.5kg	
Warranty	12 months	

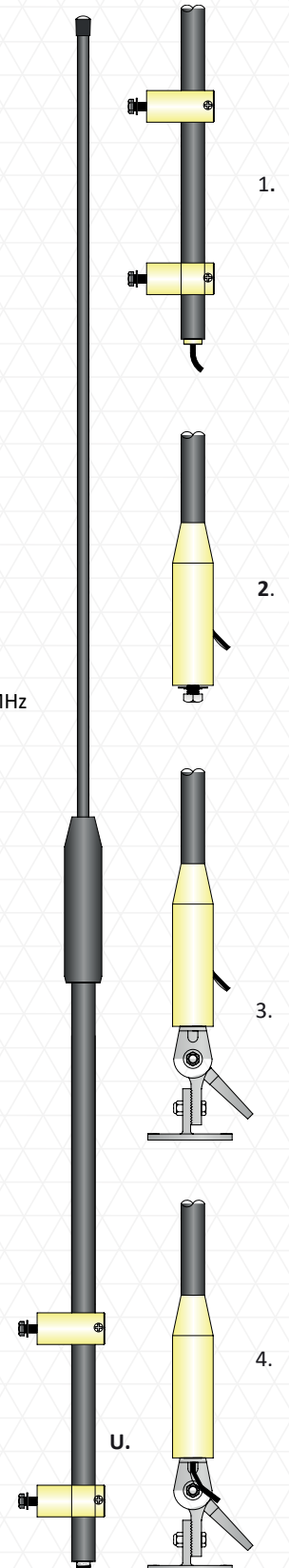

marine use only, it can be supplied resonant at 156.8 MHz (Channel 16) as in the past, but the recommended and now standard configuration is resonant at 158 MHz to include the usual vessel transmit frequencies (156.025 – 157.425 MHz) as well as the frequencies of AIS transmitters (161.975 and 162.025 MHz). This also allows the AIS antenna to be used as a backup emergency/VHF antenna if required. A compact collapsible portable version is also available on special order for emergency services (type MD Portable).

Mounting:**SWINGDOWN MOUNT**

1. Place the base plate of the mount in the desired position and use it as a template.
2. Mark the position of the mounting holes.
3. Drill 4 x 6.4mm (1/4 in) dia holes.
4. Bolt the mount/antenna in place

M12 BASE MOUNT ADAPTOR

1. Mark the mounting position on a horizontal surface or mount and drill a 12mm hole in the marked position.
2. Using a 12mm (metric thread) stainless steel or galvanised bolt, fasten antenna down firmly.

SIDE MOUNTING

1. For sidemount insulators: slide the two mounts onto the mounting tube. Mounts should be spaced not less than 25cm apart.
2. Mark the positions and drill the holes for the sidemount set bolts
3. Hose clamps or similar may be used to mount the antenna to a mounting pole, however suitable insulation should be used to prevent metal to metal contact.
4. Do not over tighten straps or clamps so as to damage the coating or crush mounting tube.
5. Keep antennas matching coil clear of support pole.

Important Factors:

1. The mounting tube must not be drilled or damaged in any way.
2. The antenna should be mounted as high as possible and kept clear of nearby metal objects which may affect antenna tuning, and for best results, should be vertical, not sloping.
3. Note that due to the internal arrangements in this antenna it will exhibit a short circuit if tested with an Ohmmeter or DC circuit tester between inner and outer of coaxial cable.
4. Ensure coaxial connections are sealed against water ingress.
5. Do not allow the coaxial connector to take the cable strain. Secure cable with cable ties or tape.
6. When using a swingdown mount allow sufficient coaxial cable slack to permit antenna to swingdown without cable strain.

CBG Systems

9 Bender Drive, Derwent Park
Tasmania, AUSTRALIA 7009

T +61 3 6272 6105

F +61 3 6273 1716

E info@cbgsystems.com

www.cbgsystems.com

Moonraker products represent the pinnacle of antenna design. With over 45 years' experience supplying Defence, Commercial and Recreational industries. Moonraker antennas are individually tuned and manufactured to our stringent extreme marine quality standards that ensure maximum performance and service life.

