



HF RXDPA

ACTIVE BROADBAND RECEIVE ANTENNA

Designed to provide compact efficient HF broadband reception from 0.01 to 30 MHz over short, medium and long range distances simultaneously, being capable of receiving high (NVIS) through to low angle signals.

The HF RXDPA antenna system comprises two separate antennas mounted on a single support mast with separate feeds. Output from the antennas is fed directly to two broadband amplifiers.

When erected onboard ship or at ground level, the array is suitable for simultaneous reception of both high angle (NVIS) mode and low angle long distance communications. Erected on buildings, it is possible to reduce local interference by careful positioning to null out unwanted signals. By using multiple antennas mounted at different angles with a suitable switching network into a receiver, it is possible to determine direction of signals. Over voltage protection (lightning/EMP) is provided.

The antenna is constructed using heavy gauge marine grade aluminium alloy. The radiator and base are finished with a finish that is resistant chemical attack, abrasion and the effects of ozone and ultra-violet radiation.

For ease of transportation the antenna breaks down into three easy to assemble sections. The support mast is available in 2 or 3 metre lengths or as required for ease of shipboard siting.

SPECIFICATIONS ▼

	STANDARD	
Colour	APO Grey Colours available to order (Optional)	
Antenna Elements	Vertical; 1 x 1010mm Horizontal; 2 x 620mm	
Antenna Height	3.65m or 2.65m, depending on choice of support mast (Optional)	
Radiators	Active Monopole	Active Dipole
Frequency Range	0.010 to 30 MHz	0.10 to 30 MHz
Gain (nominal)	5.5dB +/- 1dB depending on frequency. Note: lower frequencies will show negative gain as amplifier is being used mainly as a matching device.	
Polarisation	Vertical	Horizontal
Radiation Pattern	Omnidirectional	Bi-directional
Output Impedance	50Ω Nominal	
Output Intercept Point	2nd Order = 66 dBm; 3rd Order = 36 dBm	
Connectors	N Type Sockets	
Supply Voltage	11-14v DC @ 140 mA via each coaxial cable	
Power Supply Unit	Output Voltage; 12v DC Input Voltage; as required 12-24v DC (Optional)	
Support Mast	2 or 3 metres (Optional)	
Weight: Antenna	4.4kg; packed 5.6kg	
Weight: Mast	9.2kg; packed 19kg	
Operating Temperature	-40° to +70°C, relative humidity 100%	
Wind Survival	200 km/h	

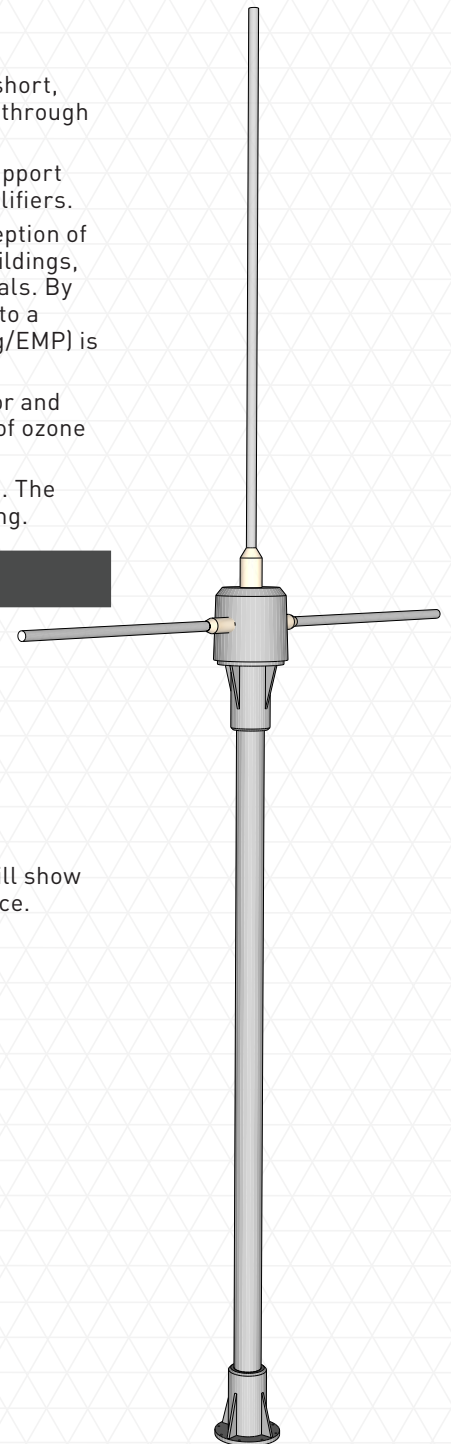

CONTACT DETAILS ▼

CBG Systems

9 Bender Drive, Derwent Park
Tasmania, AUSTRALIA 7009

T +61 3 6272 6105

F +61 3 6273 1716

E info@cbgsystems.com

www.cbgsystems.com

Moonraker products represent the pinnacle of antenna design. With over 45 years' experience supplying Defence, Commercial and Recreational industries. Moonraker antennas are individually tuned and manufactured to our stringent extreme marine quality standards that ensure maximum performance and service life.



CBGSystems