



# 80B - 80B/S - 80W

### MARINE HF WHIP ANTENNA FOR PROFESSIONAL AND GMDSS USE ON OCEAN GOING VESSELS.

The 80 series is a 8 metre (26.2 ft) heavy duty free standing whip antenna with a power capability of 1.0 kW PEP in the frequency range 1.6-30 MHz, designed to provide efficient and reliable communications in the professional services where a 10 metre (100 series) antenna is not suitable.

The antenna is available either side mounted (80W) or base mounted with base feed (80B) or side feed (80B/S) and is able to withstand wind speeds of 200 km/h without permanent deformation.

Construction is of heavy gauge marine grade aluminium alloy tubing, which provides a large low loss surface area for maximum radiating efficiency. The radiator and base flange are finished with a high durability epoxy based coating, highly resistant to chemical attack, abrasion and the effects of ozone and ultra-violet radiation.

The base mount is fabricated aluminium alloy with industry standard 165 mm O/D flange with eight mounting holes, drilled on 140 mm centres. Base insulator is ribbed high strength low loss polypropylene. Side mounting is via two ribbed low loss polypropylene insulators. Connection is via a base feedthrough insulator (B) or to a stainless steel side terminal above the base insulator (B/S) or bottom side mount (W).

For ease of transport, the antenna breaks down into three sections which slip together and fasten with stainless steel locking screws. These joints are sealed using a special jointing kit and covered with flexible boots.

### SPECIFICATIONS ▼

	STANDARD	OPTIONAL
<b>Colour</b>	Black	Grey or White
<b>HF Marine Band</b>	1.6-30 MHz	
<b>Length</b>	8.0 metres (26.2 ft)	
<b>Pattern</b>	Omnidirectional	
<b>Polarisation</b>	Vertical	
<b>Frequency Range</b>	Unloaded 1.6-30 MHz with suitable ATU	
<b>Wind Loading</b>	66 kg at 200 km/h Antenna survival: 200 km/h, 55m/sec	
<b>Tip Deflection</b>	4 m at 200 km/h, 55m/sec	
<b>Power Capability</b>	1.0 kW PEP	
<b>Base Mounting</b>	Industry standard 165 mm diameter flange with 8 x 13.5 mm (1/2 in) holes drilled on a 140 mm diameter	
<b>Side Mounting</b>	Two 5/8 in Whitworth bolts into two 110 mm diameter side mounting insulators, spaced a minimum of 1 m apart.	
<b>Connection</b>	Side feed via 1/4 in Whitworth stainless steel stud and lock nuts, base feed below through deckmount via 3/8in Whit s/s stud and locknuts	
<b>Packed Weight</b>	80B: 31 kg, 80B/S: 28 kg, 80W: 19 kg	

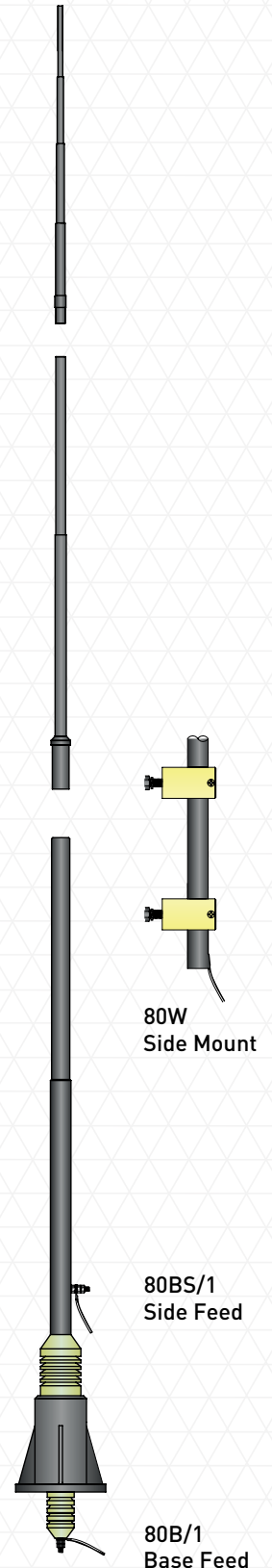

**ANTENNA JOINT SEALING KIT****The kit will consist of the following:**

- 1 x upper joint shroud - small
- 1 x lower joint shroud - large
- 1 x container of special grease - antenna joint
- Roll of special tape - antenna joint
- O-ring - large

**Other items required but not supplied:**

- 1 x pair scissors
- 1 x Philips head screw driver
- Rags - lint free
- Cleaning fluid (general purpose)
- Lubricant (detergent and water)

**CBG Systems**

9 Bender Drive, Derwent Park  
Tasmania, AUSTRALIA 7009

**T** +61 3 6272 6105

**F** +61 3 6273 1716

**E** info@cbgsystems.com

**www.cbgsystems.com**

**Antenna Section joining:**

The object of this procedure is to exclude moisture from the joints of the antenna. **Strict adherence** to the instructions will prolong service life and ease disassembly of the antenna in years to come.

**Note:** When handling antenna ensure that hands and tools are clean. Wipe any dirt, grease etcetera from antenna using clean rag soaked in cleaning fluid.

Ensure antenna sections are adequately supported and are not knocked or scraped against any hard surfaces. If necessary, place protective wrapping around antenna to prevent damage to surface finish. The following instructions apply to both joints, we suggest assembly of bottom joint first.

**Note 1:** That only the bottom joint is fitted with an "O" ring seal.

**Note 2:** Synthetic rubber joint shroud material has a high tear resistance but do not stretch it more than necessary or use sharp objects to manipulate it.

**Joint Sealing:**

1. Remove fixing screws from joint section.
2. Lightly lubricate the external surface of the joint section with detergent and water (or similar).
3. Carefully slide the joint shroud over the antenna to the upper section of the joint to a point approximately 200mm above the joint.
4. Roll larger diameter section of joint shroud back over itself until the shroud is the length of the smaller diameter section.
5. Thoroughly clean mating surfaces of the joint and remove the detergent and water using rag and cleaning fluid and allow to dry. Ensure no dust or residue is left on surfaces.
6. Install "O" ring on upper section of joint in the "O" ring groove provided. (Base to mid section only) Use normal precautions observed for "O" rings to prevent damage such as nicks and abrasions.
7. Apply the conductive grease to both surfaces of joint using special grease supplied in jointing kit. Work grease around "O" ring.
8. Carefully insert upper section into lower section, gently rotate upper section to ensure even distribution of jointing grease.
9. Align joint fixing holes, insert fixing screws with internal star washers (base to mid section only) and tighten firmly.
10. Thoroughly clean excess grease from external surfaces of antenna using rag and cleaning fluid – allow to dry.
11. Wind the special tape supplied firmly (without stretching) once around antenna immediately below fixing screws and then spirally wind tape towards antenna joint, keeping tape firm. Each winding to step up by half the tape width until a position just above the joint is reached.
 

Proper adherence to this procedure will ensure that the screws and joint are properly sealed.
12. Slide down and manipulate the shroud over the upper section of the joint. Roll the larger diameter section over lower section of joint. Manipulate the shroud until it is fully home on both diameters.
13. Thoroughly clean all excess lubricant from antenna using a dry rag.

Moonraker products represent the pinnacle of antenna design. With over 45 years' experience supplying Defence, Commercial and Recreational industries. Moonraker antennas are individually tuned and manufactured to our stringent extreme marine quality standards that ensure maximum performance and service life.



**80B HF INSTALLATION INSTRUCTIONS ▼**

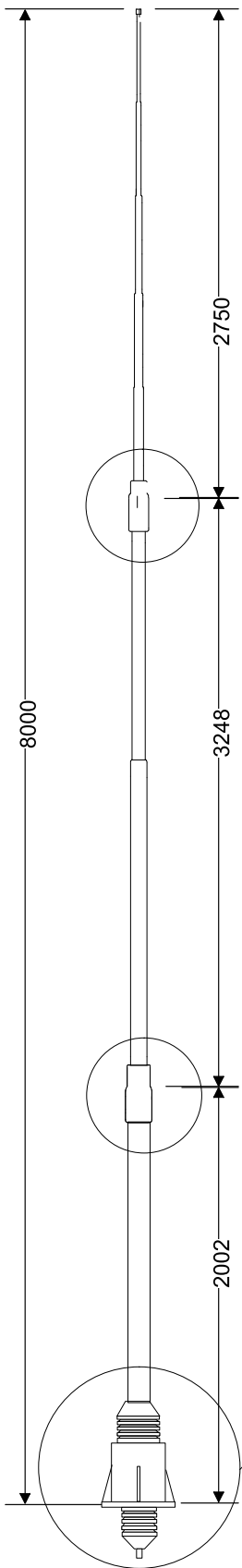

**HOLES:**  
 8 x 13.5mm diameter  
 at 45 degrees  
 1 x 75/80mm diameter  
 for feedthrough  
 insulator

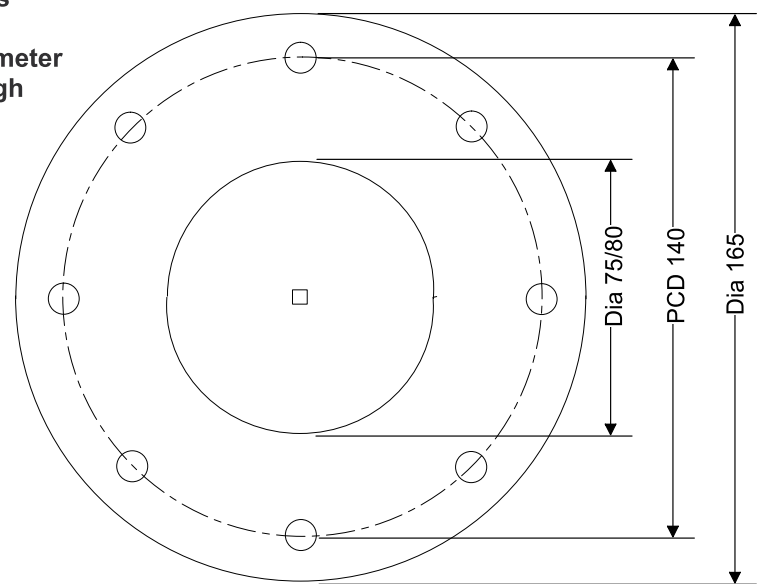

**BASE MOUNT**  
 Mounting Flange

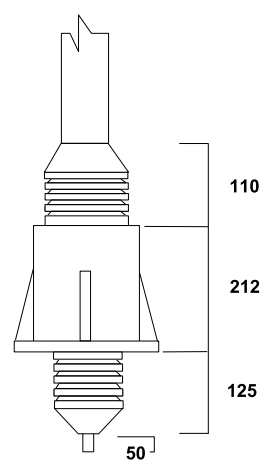

**DETAIL A**  
 FEED POINT

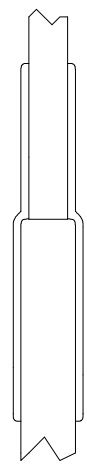

**DETAIL B**  
 JOINT SEALING SHROUD  
 Tape should be wound to cover screws and joint first then place rubber shroud over the joint -  
 See Installation Instructions

DIMENSIONS IN MILLIMETRES  
 UNLESS SHOWN OTHERWISE

GLE	16/ 02/ 12		SCALE	NTS	
	/ /		DES,ND	LWE 10/93	
	/ /		DRAWN	GLE	
REV	BY	DATE	REVISION DESCRIPTION	APPR'D	7/00

<b>MOONRAKER AUSTRALIA PTY LTD</b>	
HOBART AUSTRALIA	
<b>TYPE 80B HF ANTENNA</b>	
<b>INSTALLATION DETAILS</b>	
DRAWING NUMBER	REV
UNCONTROLLED COPY	

**80B/S HF INSTALLATION INSTRUCTIONS ▼**

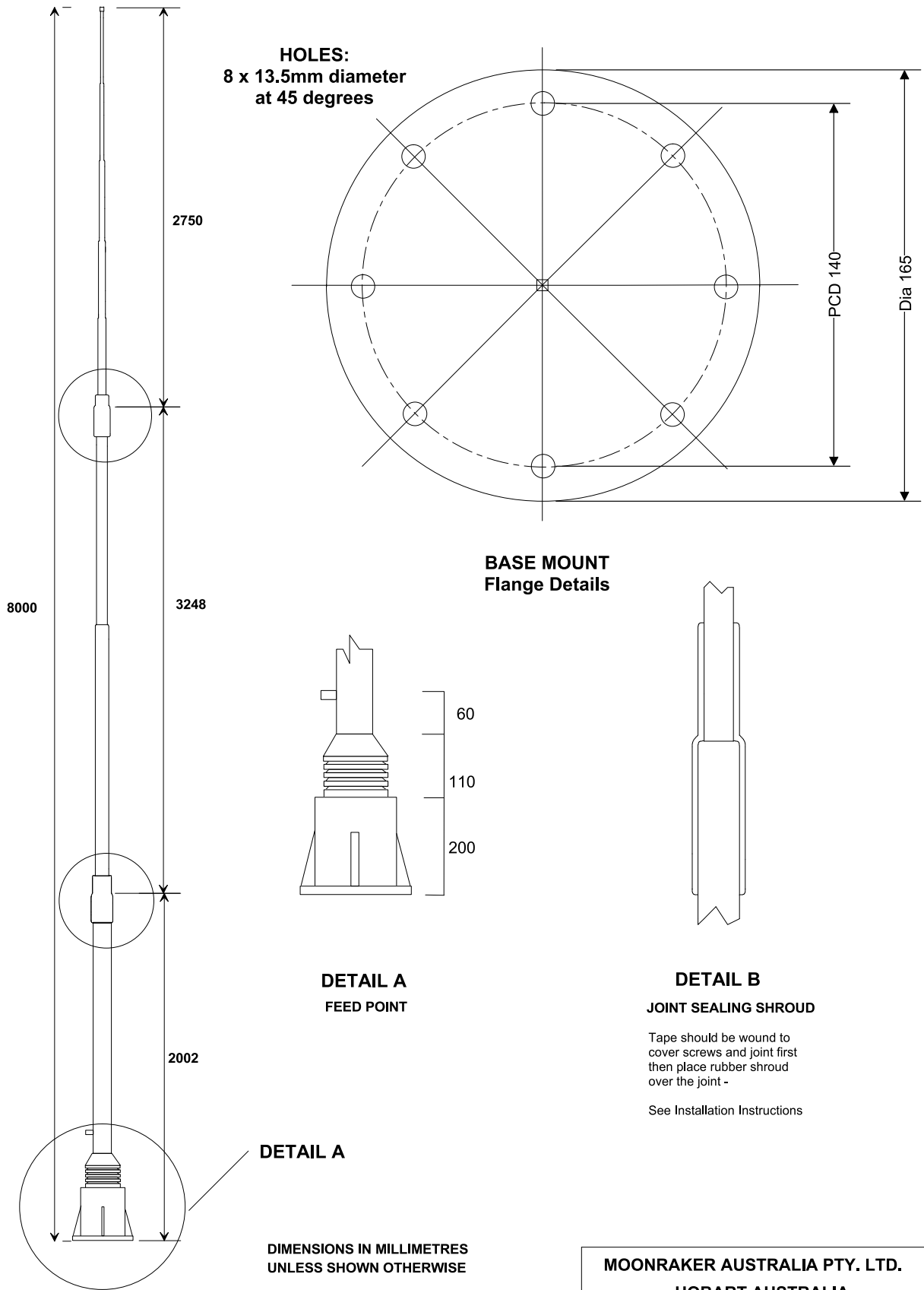

GLE	21 / 02 / 12		SCALE	NTS	<b>MOONRAKER AUSTRALIA PTY. LTD.</b> <b>HOBART AUSTRALIA</b> <b>TYPE 80B/S HF ANTENNA</b> <b>INSTALLATION DETAILS</b>	
	/ /		DES,ND	LWE/RK 97		
	/ /		DRAWN	GLE		
REV BY	DATE	REVISION DESCRIPTION	APPR'D	7/00	DRAWING NUMBER UNCONTROLLED COPY	REV